

MATHIUS

SHAW-W-SKY

ON - TENSION - T

MUSIQUE DU CORPS SUR LUI-MÊME

<p>Posture Mouvement</p> <p>PERCUSSION</p> <p>[Circulation du sang] Respiration</p> <p>[Battements du cœur]</p>	<p>x 7</p> <p>Immobilisé Debout Raide Le regard fixe droit devant Prêt à jouer, baguettes posées sur les peaux des toms</p> <p>Silence total</p> <p>Poumons vides retenus</p> <p>• 7; 7; 7; 7; 7; 7; forcé, nasal</p>	<p>7"</p> <p>micro sur intestin (stéthoscope) baladeur micro sur la gorge micro sous le nez micro sur le cœur micro devant la bouche</p> <p>Contractions</p> <p>(Vitres) + bac de graviers</p> <p>Enfoncement</p> <p>Pieds</p> <p>+ bac de sable</p> <p>3p frisson de frottage</p> <p>Chevilles</p> <p>4p Enfoncement</p> <p>Jambes</p>
<p>Posture Mouvement</p> <p>CONTREBASSE</p> <p>[Circulation du sang] Respiration</p> <p>[Battements du cœur]</p>	<p>Vide Immobilisé Debout Raide Le regard fixe droit devant Prêt à jouer Totalemtent détendu</p> <p>L'archet posé sans bruit sur la corde</p> <p>Silence total</p> <p>inspiration</p> <p>expiration</p>	<p>On ne voit pas l'archet bouger</p> <p>Son très lointain</p> <p>Son harmonique pur lisse + Sourdine</p> <p>Pratiquement imperceptible</p> <p>lache, nasal</p> <p>forcé</p> <p>lache</p> <p>forcé</p> <p>lache</p>
<p>Posture Mouvement</p> <p>VIOLON</p> <p>[Circulation du sang] Respiration</p> <p>[Battements du cœur]</p>	<p>Vide Immobilisé Debout Droit Le regard fixe droit devant Prêt à jouer Totalemtent détendu</p> <p>L'archet posé sans bruit sur la corde</p> <p>Silence total</p>	<p>On ne voit pas l'archet bouger</p> <p>Calme total</p> <p>Son absent</p> <p>Son harmonique pur lisse + Sourdine</p> <p>Pratiquement imperceptible</p> <p>lache, nasal</p>
<p>Eclairage</p>	<p>NOIR</p>	<p>lente</p>

3p frisson de frotage
Genoux

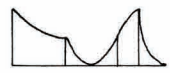

4p Enfoucement
Cuisses

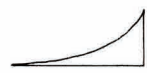

Vite + bac de graviers + bac de sable

p Enfoucement + frisson de frotage
Bassin

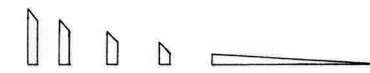

4p Enfoucement
Taille



léger serrement

7p

ral

Mouvements très lents

Enlevez la sourdine

a tempo

forcé

lache

forcé

lache

acc

forcé

lache

ral

Mouvements trop lents

Enlevez la sourdine

7p

ral

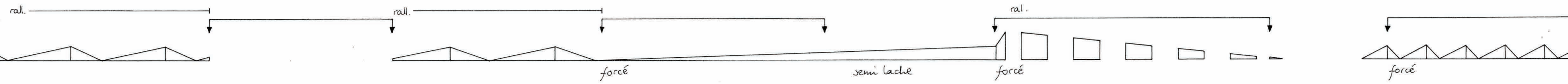
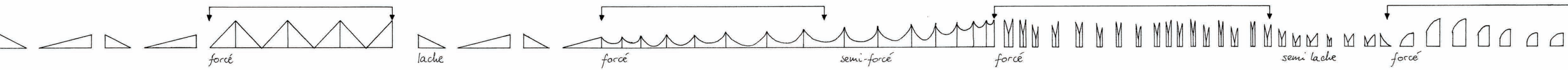
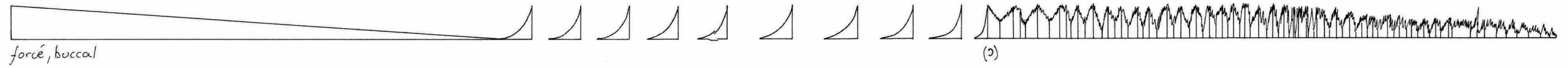
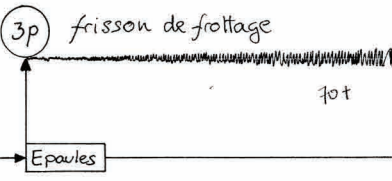
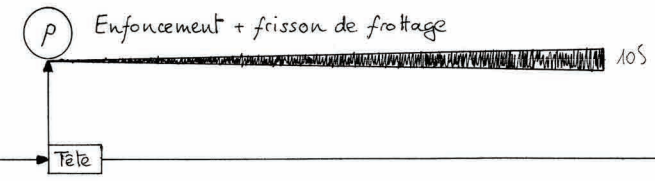
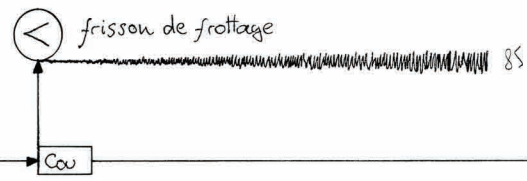
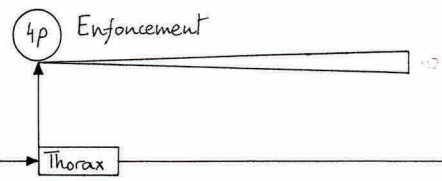

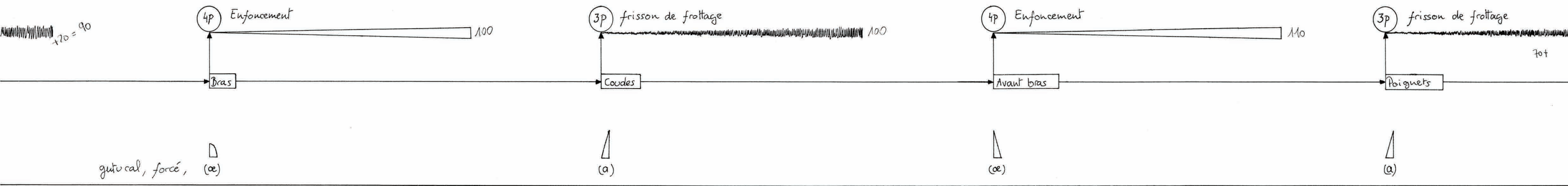

Ondulations
5p

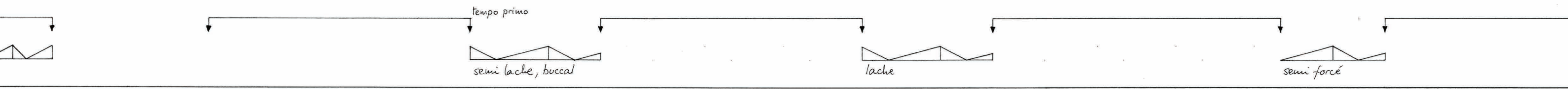
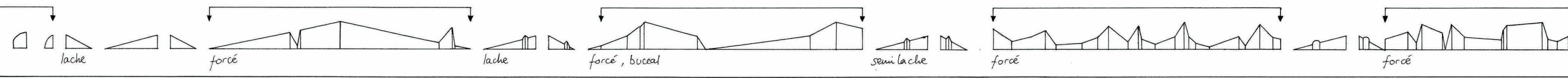

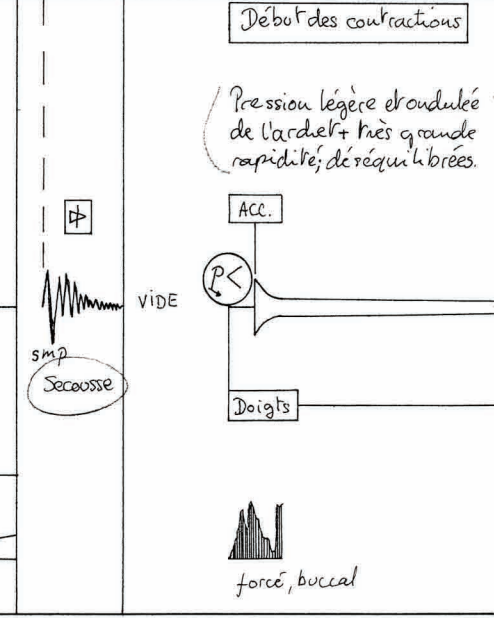
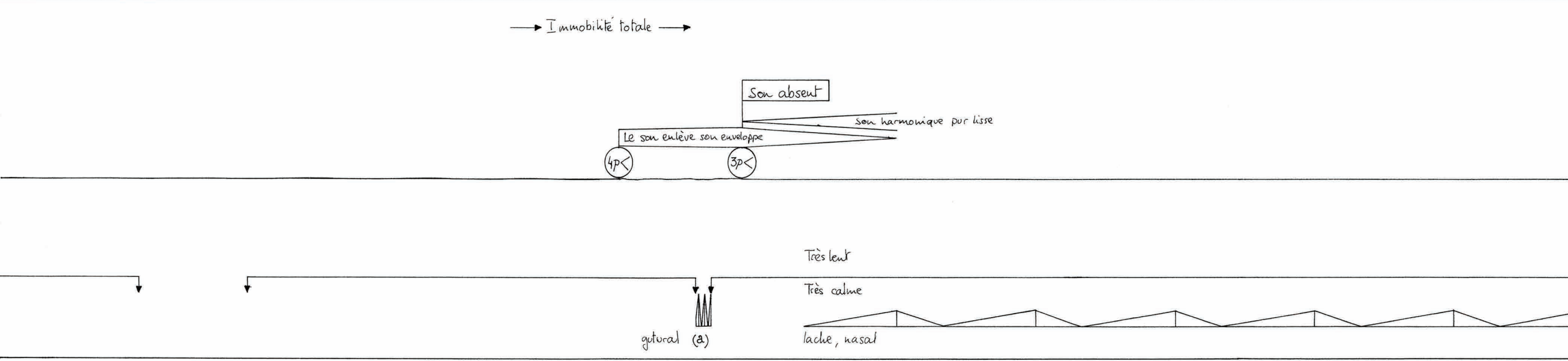
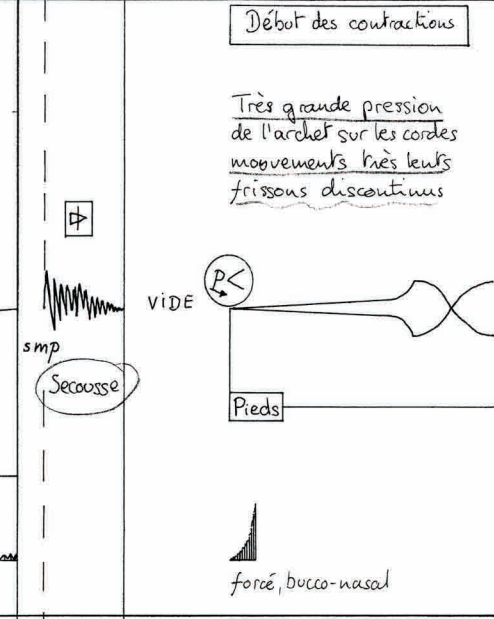
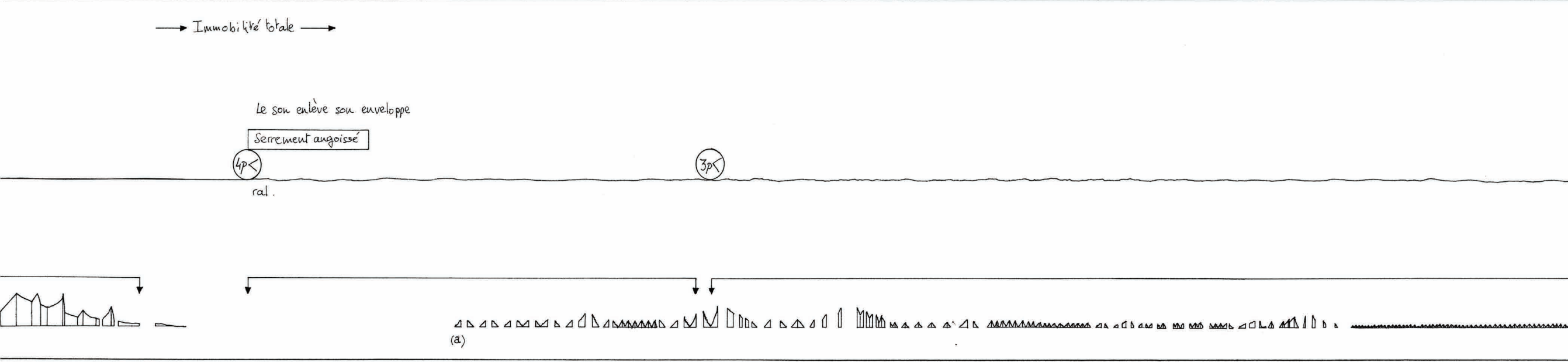
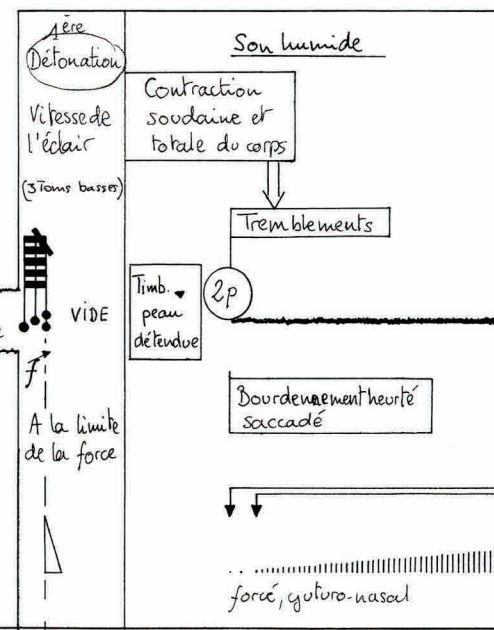
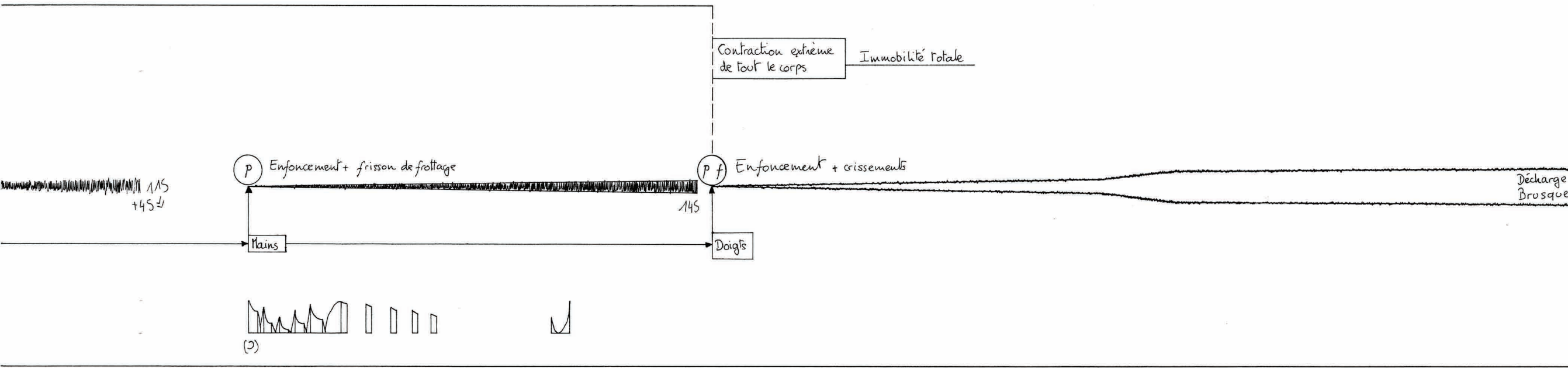

Perturbation 1

Crissant →

-feuille calque d'alu sur peau

Perturbation 2

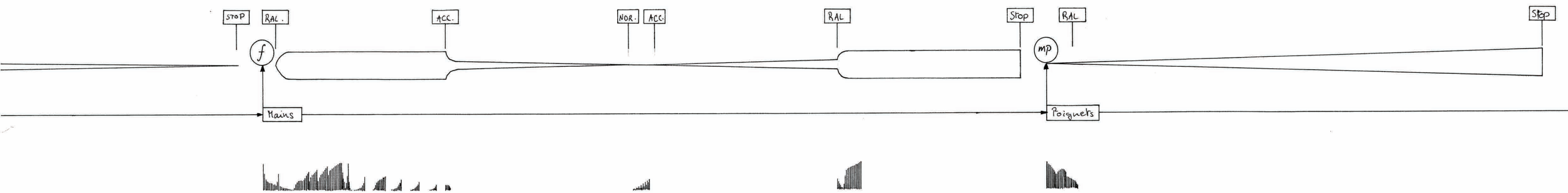
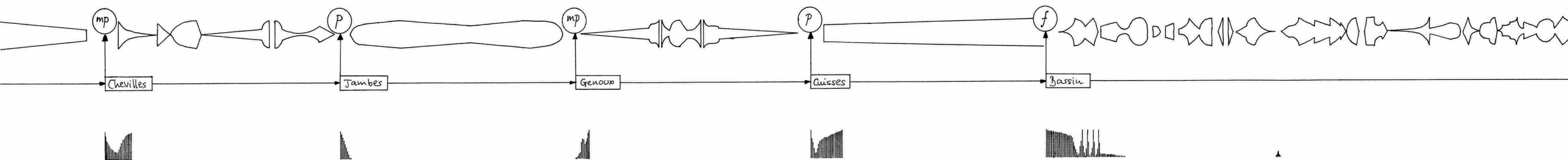
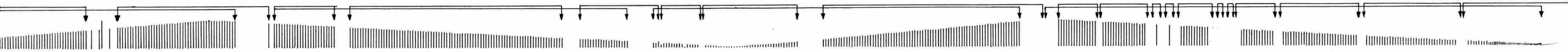

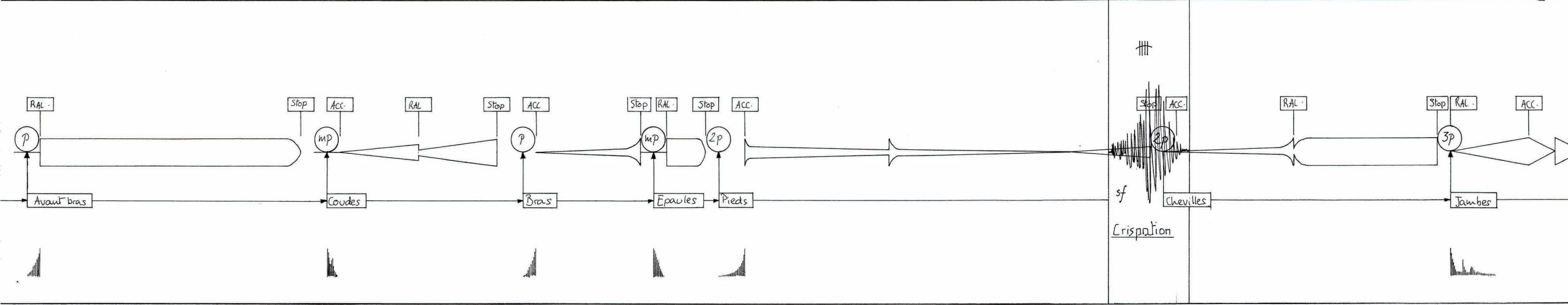
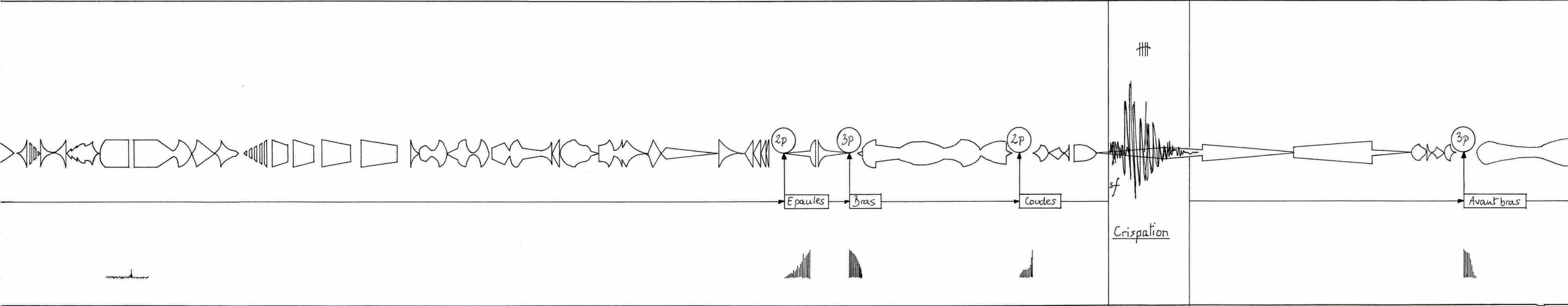
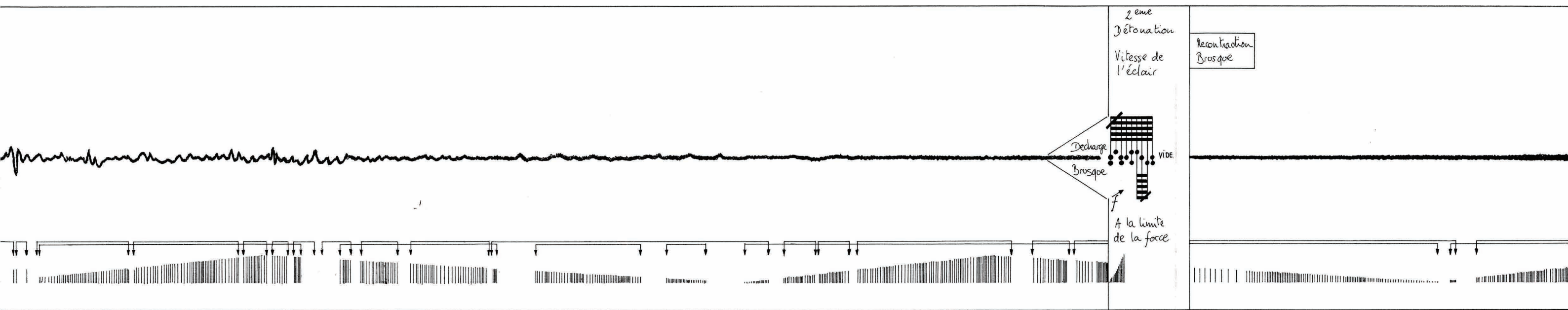

Perturbation 3

Perturbation 4

3^{ème} Détonation
Vitesse de l'éclair

Recontraction Brusque

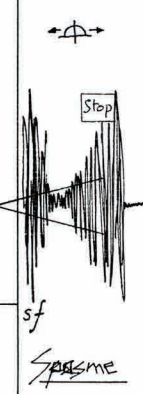
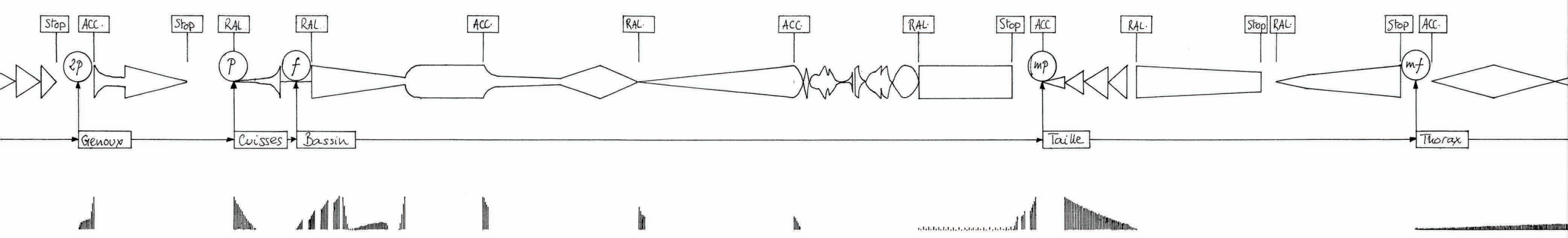
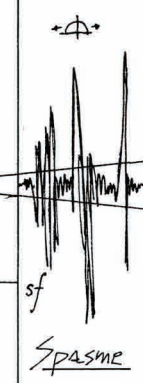
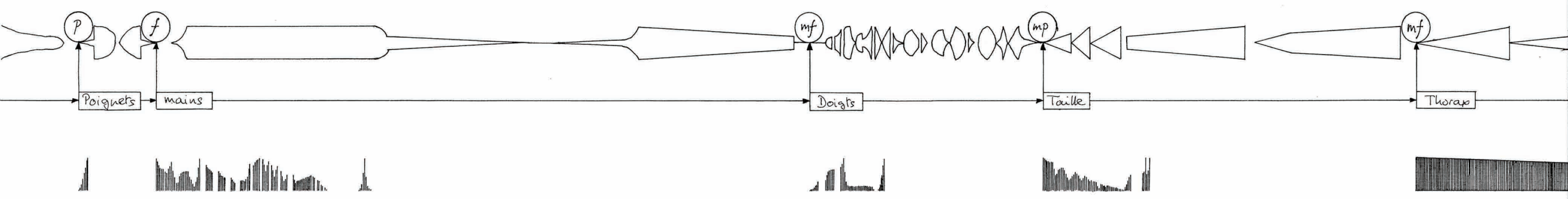
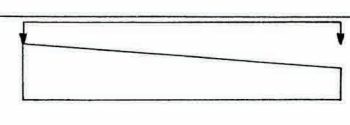
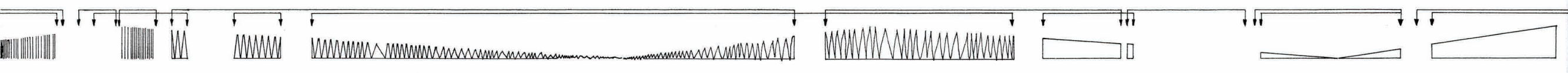
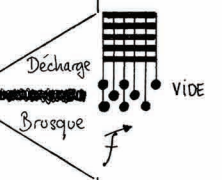

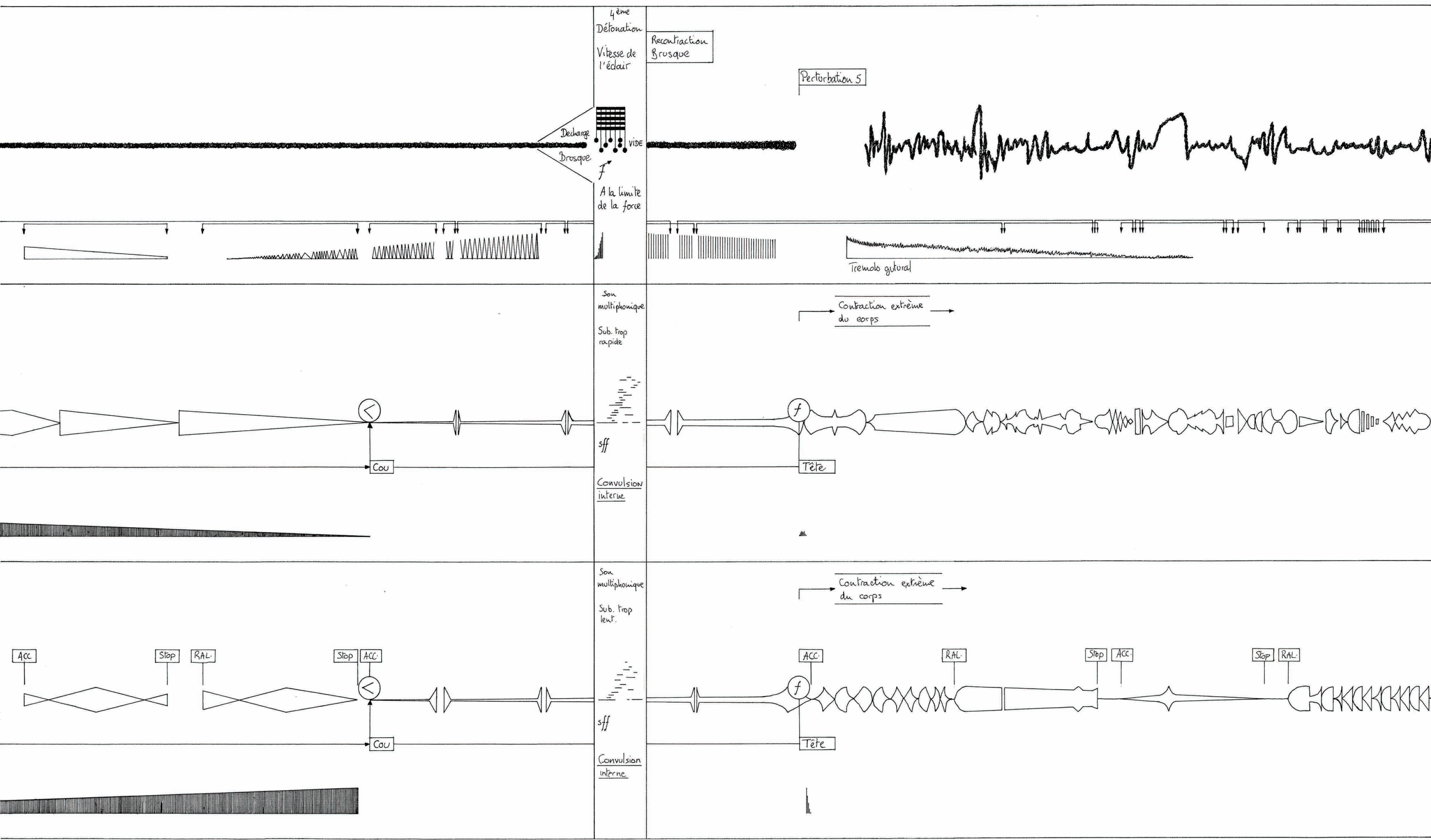

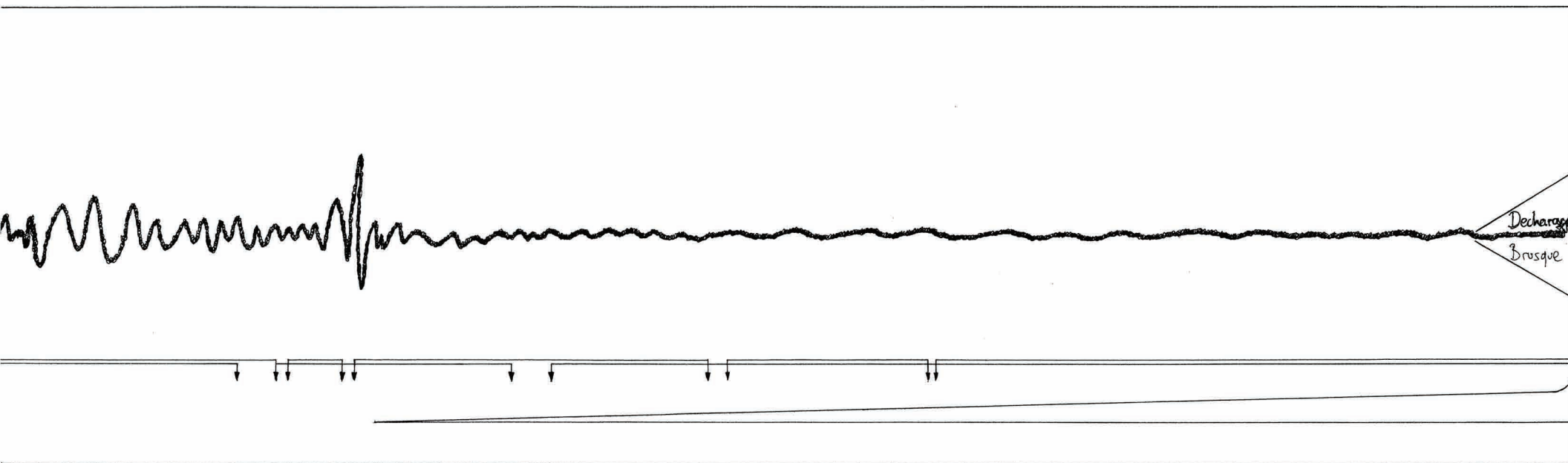

5^{ème}
Détonation
A la vitesse
de l'éclair

Décharge
Brusque

VIDE

F

A la limite
de la force

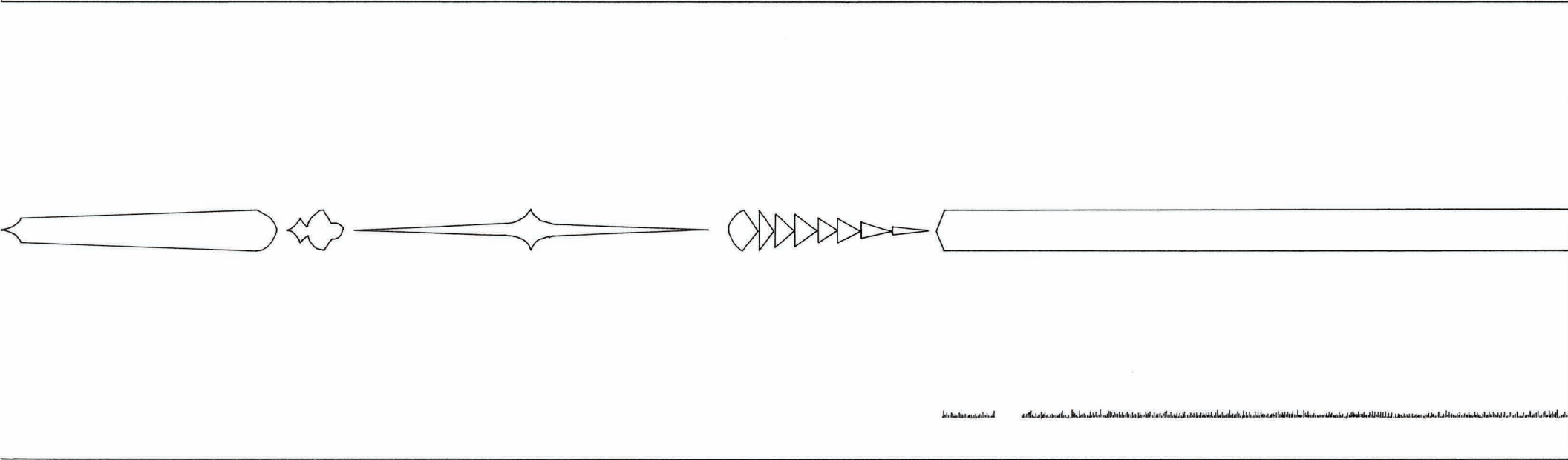
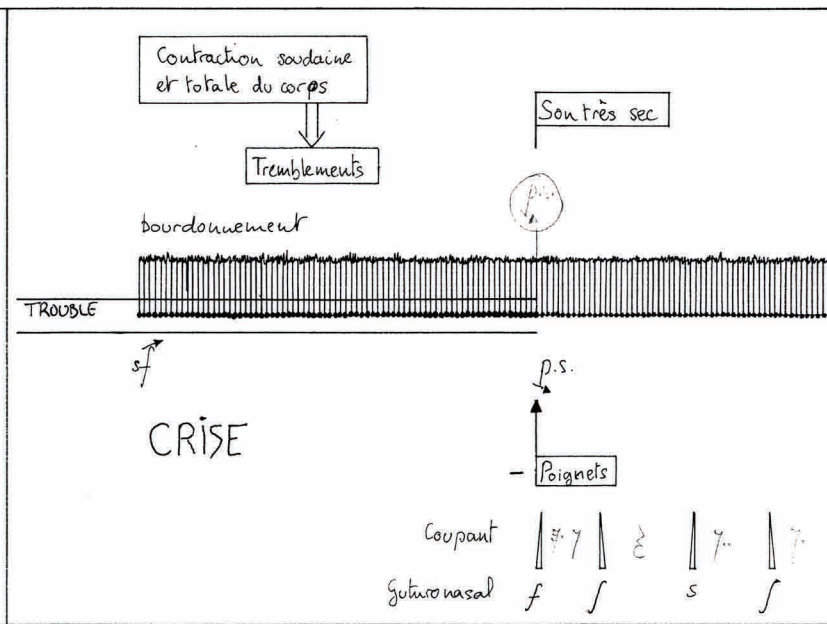

Son multiphonique

fff

Convulsion externe

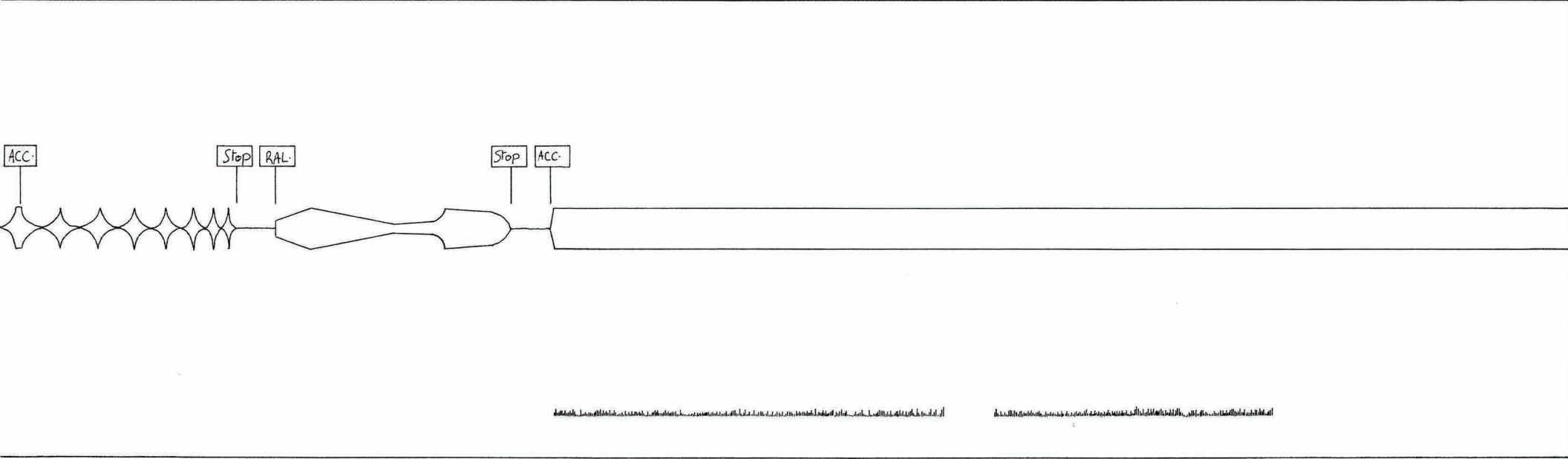
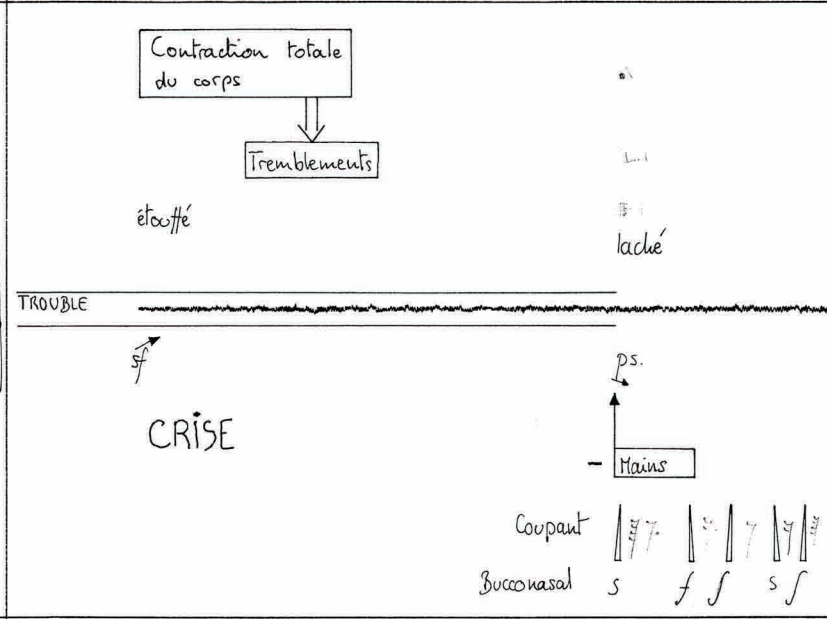

Son multiphonique

fff

Convulsion externe

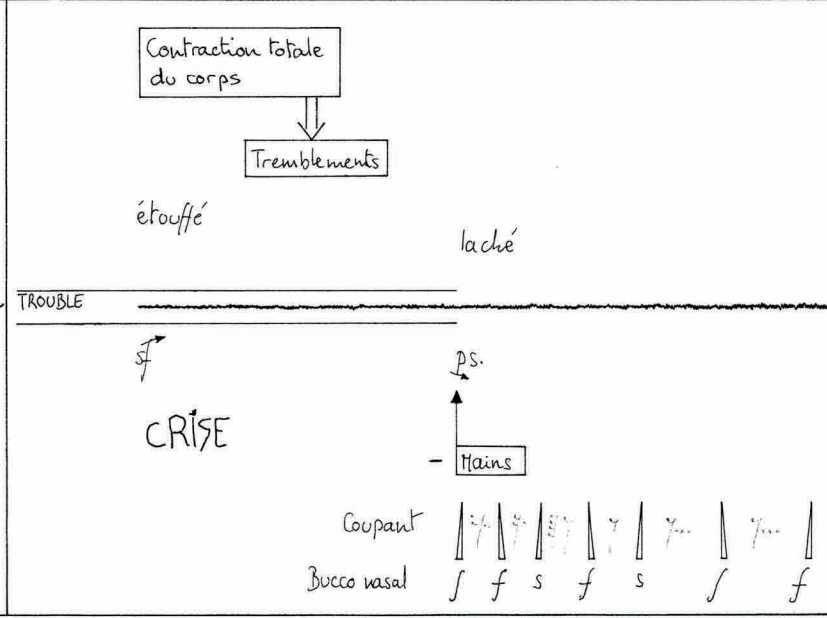

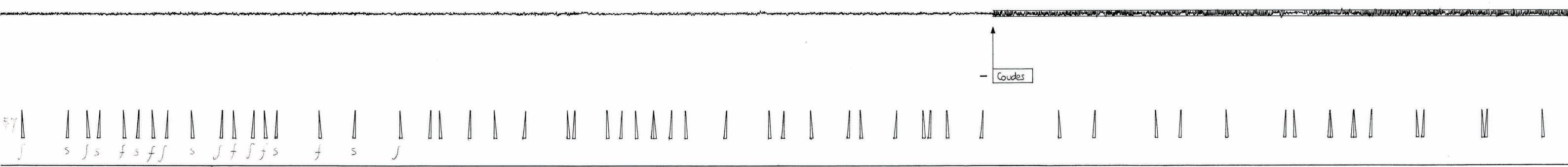
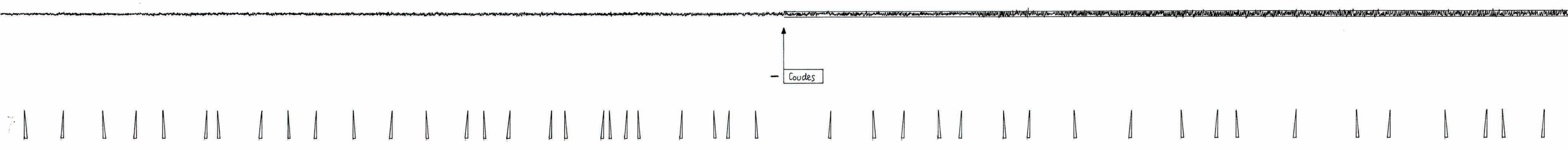
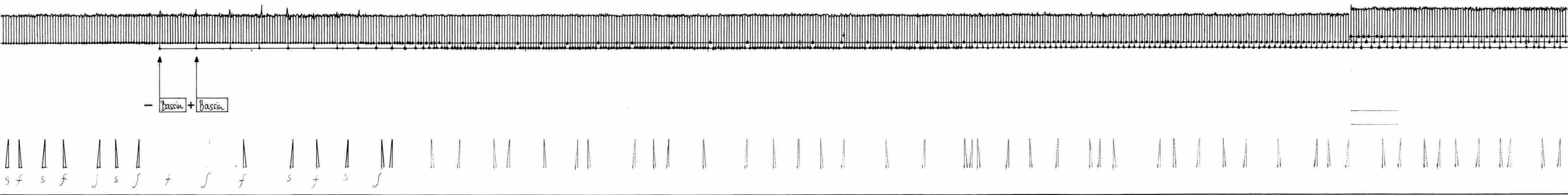

fluid attachment
PR

4 ps

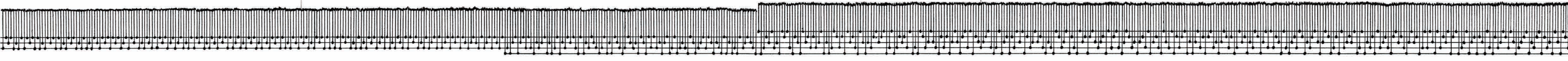

PR

4 ps

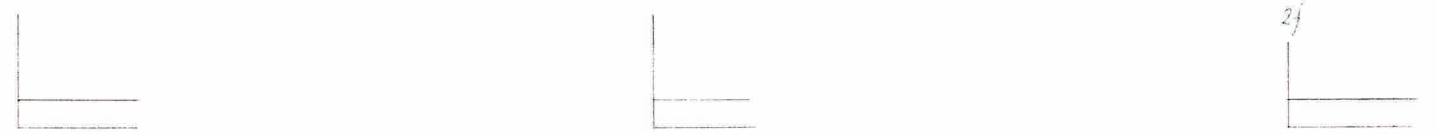
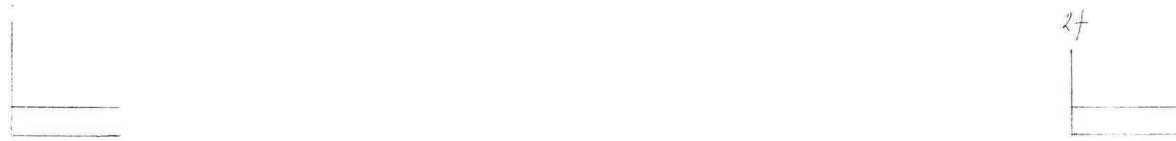

su. coupant

sp.

sp.

pc

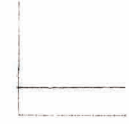
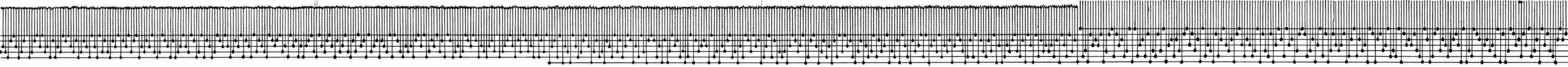

TC

TC

TC



sf

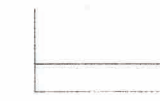
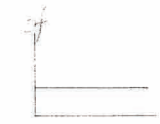
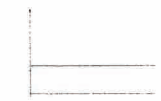
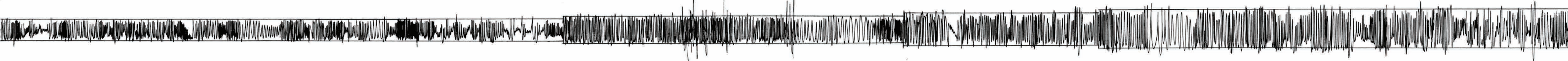

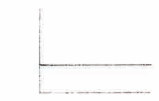
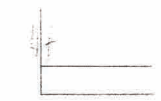
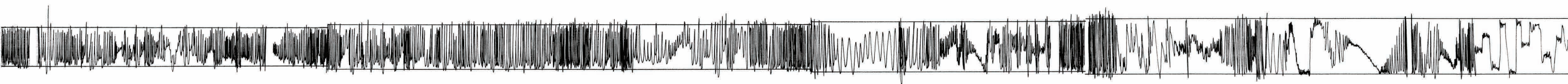
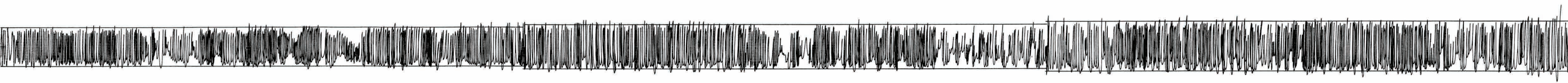
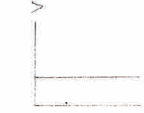
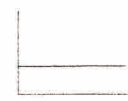
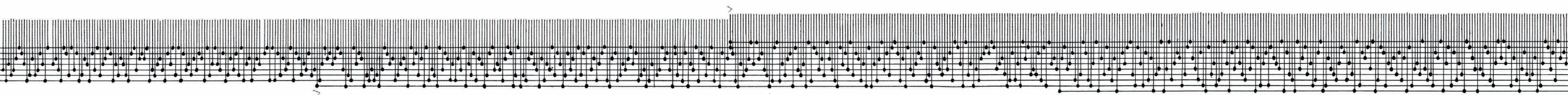

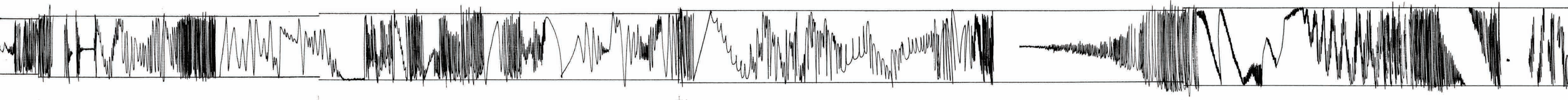
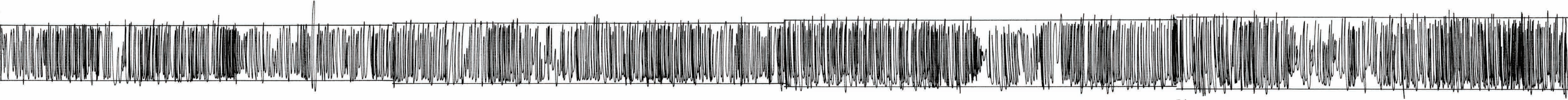
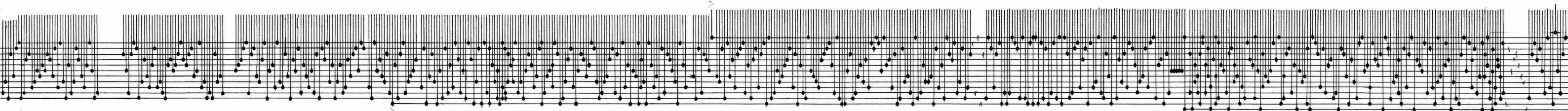

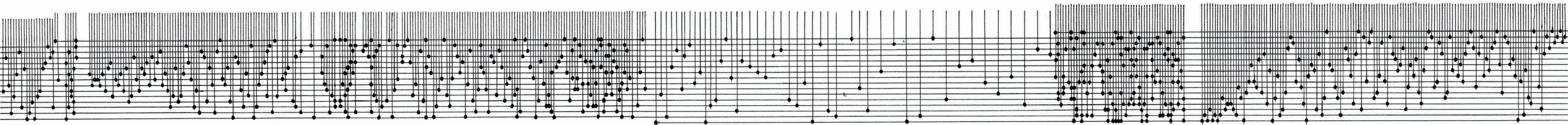

IC+DC

IC+DC

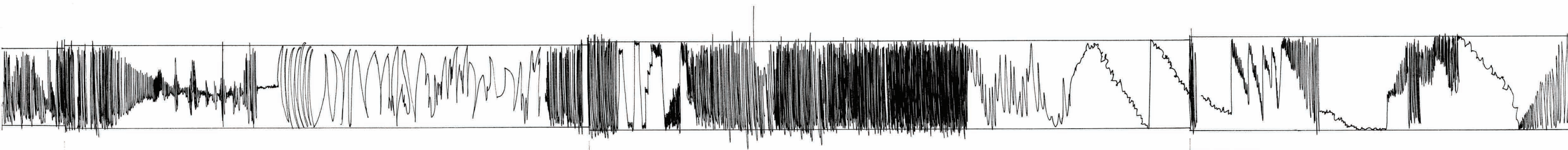
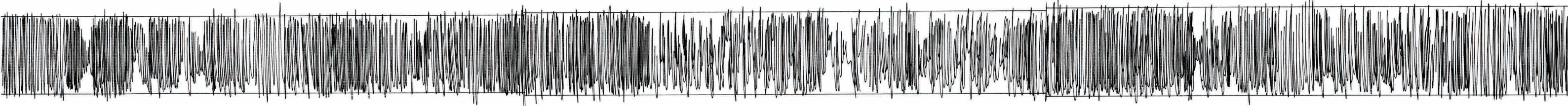

A musical staff containing a series of notes and stems, likely representing a melodic line. The notes are small black dots connected by thin stems. There are four horizontal bars below the staff, possibly indicating rests or specific rhythmic values.

Gutural archi-forcé

A musical staff filled with a dense, textured pattern of vertical lines, creating a sound effect similar to a tremolo or a heavily bowed string. There are four horizontal bars below the staff.

Gutural archi-forcé

A musical staff with a variety of textures, including dense vertical lines, wavy lines, and some more distinct notes. There are four horizontal bars below the staff. Handwritten markings above the staff include "e-f-g", "III+IV", and "ACC/FALL".

Gutural archi-forcé

4sf

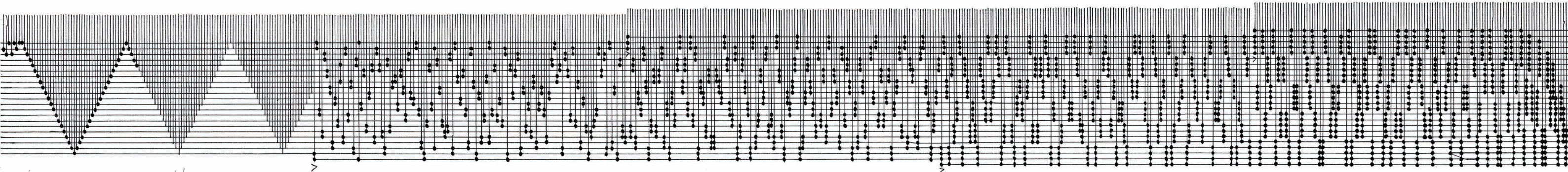

dans tube metal long
 de détresse et de desespoir déclirant
 sf subito

reverb. \emptyset

Jusqu'au dernier râle
 → max.

3f

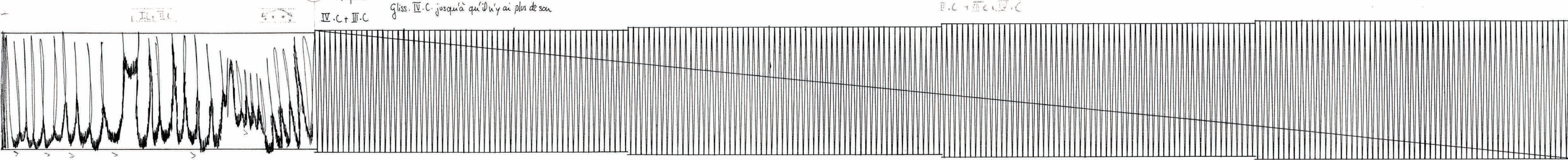

Rapoux
 IV.C + III.C
 gliss. IV.C. jusqu'à qu'il n'y ai plus de son

II.C + III.C

dans tube metal long
 de détresse et de desespoir déclirant
 sf subito

reverb. \emptyset

Jusqu'au dernier râle
 → max.

4f

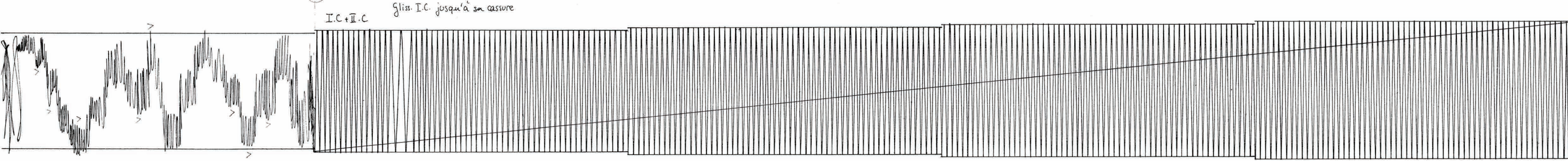

Rapoux
 I.C + II.C
 gliss. I.C. jusqu'à sa cassure

dans tube metal long
 de détresse et de desespoir déclirant
 sf subito

reverb. \emptyset

Jusqu'au dernier râle
 → max.

Sub. son sourd, lourd, étouffé

Sub. ①

la IV^e corde est retendue par palier

Tremblement extrême

voir additif

Sub. ①

2 archets

Décontraction subite
et totale

les sons glissent de partout: legatissimo.

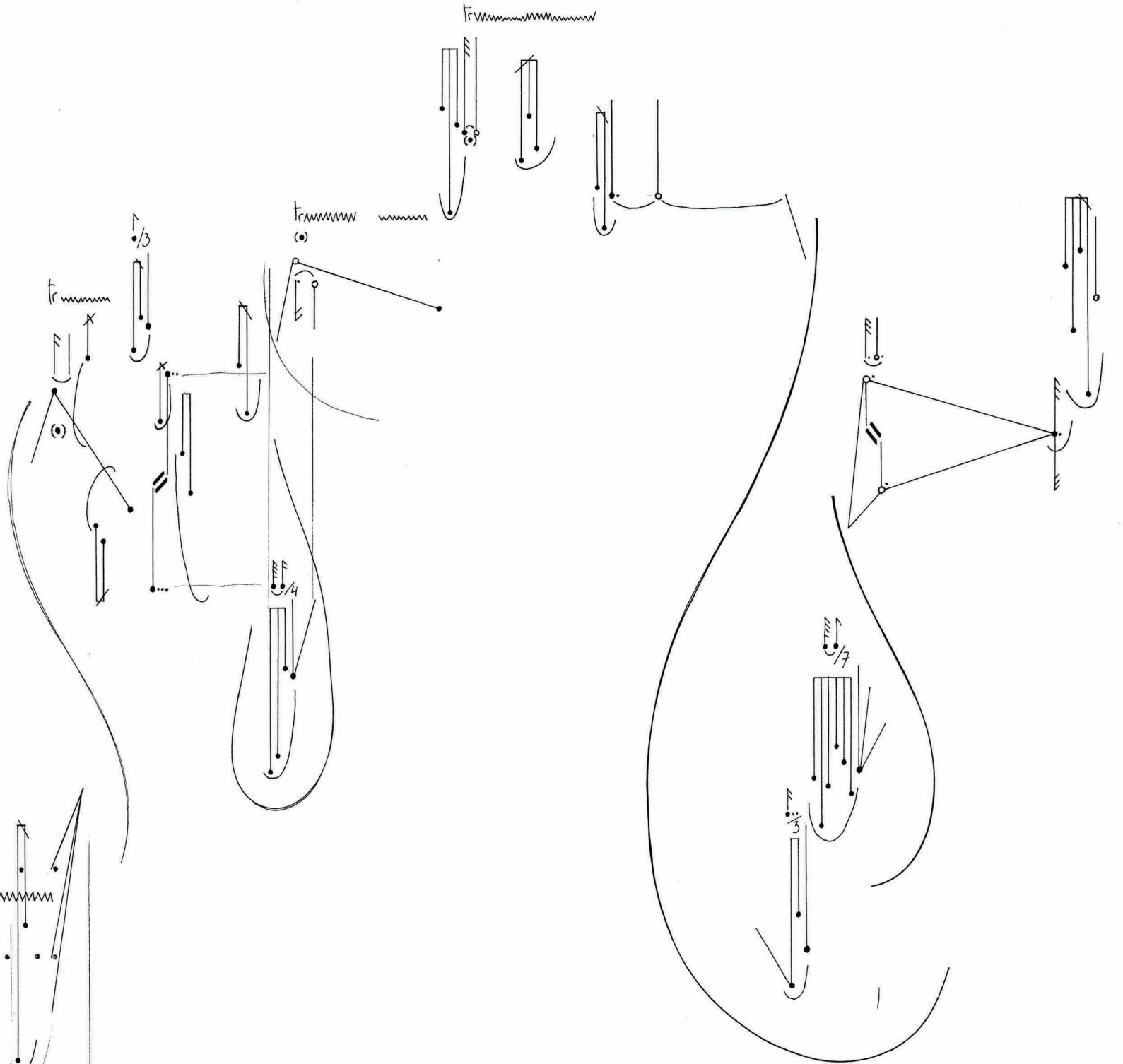
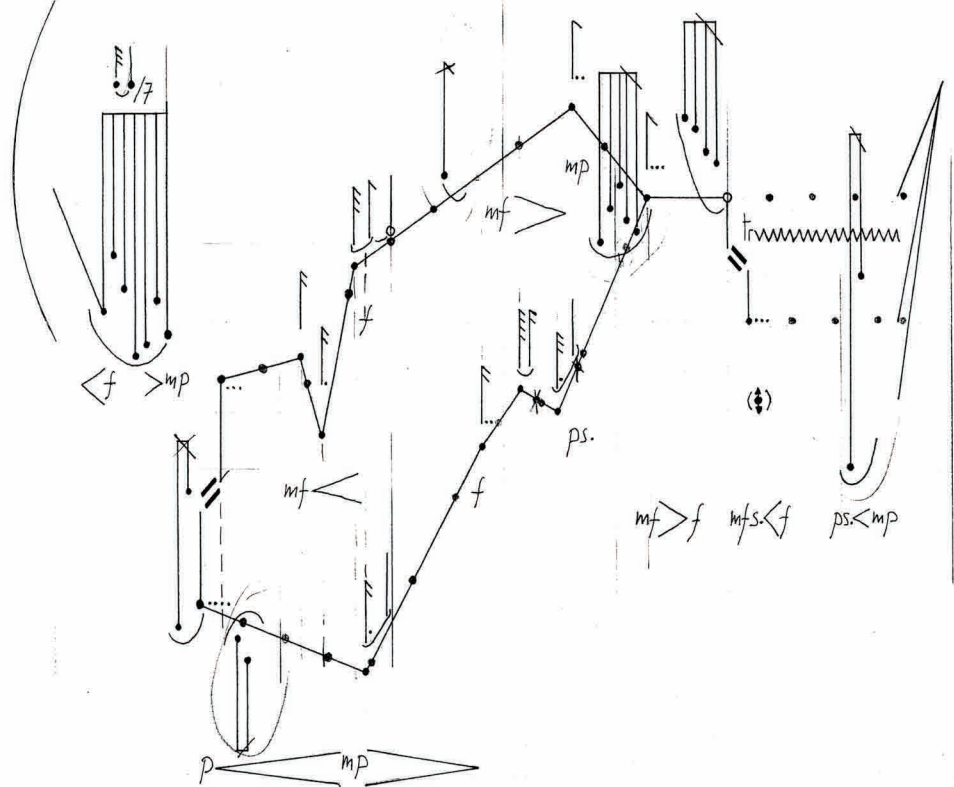
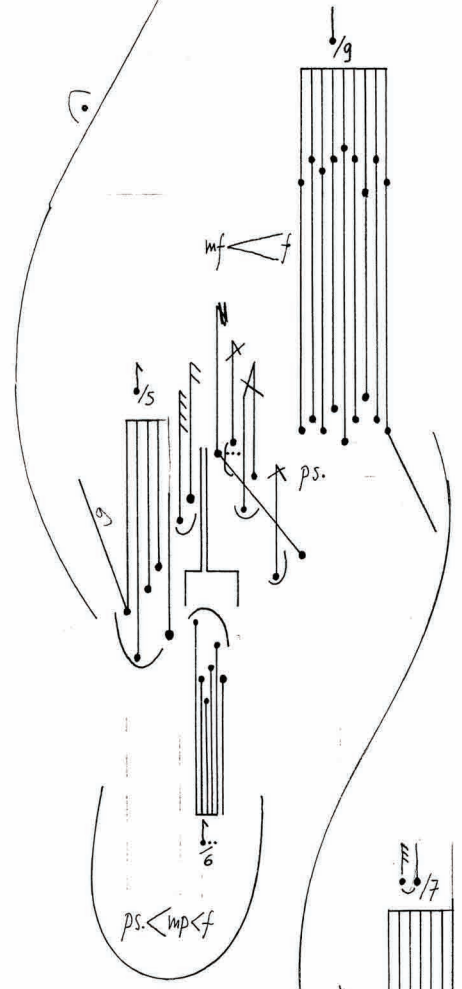
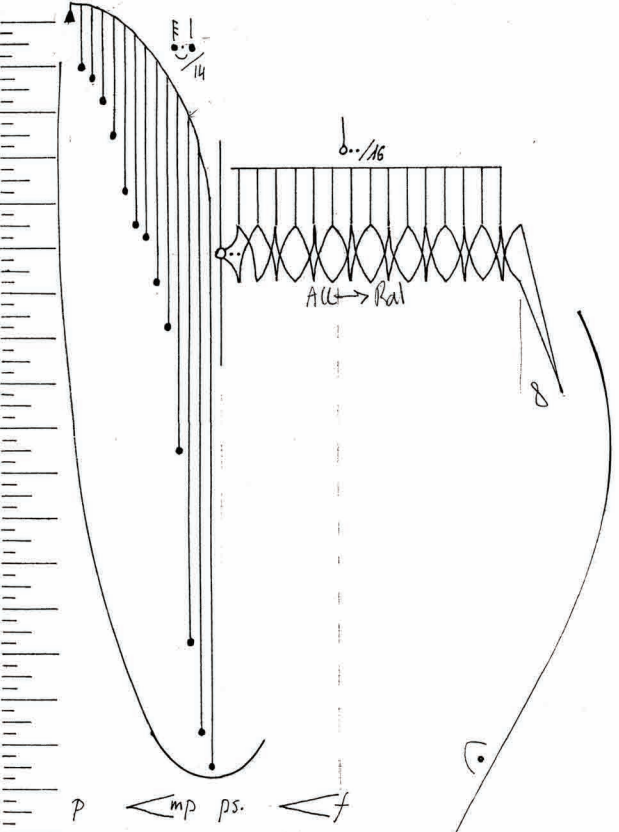

Now instable

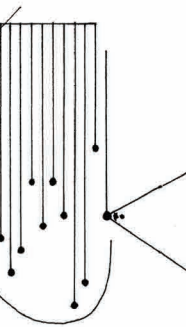
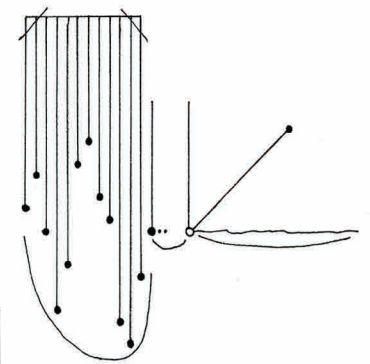
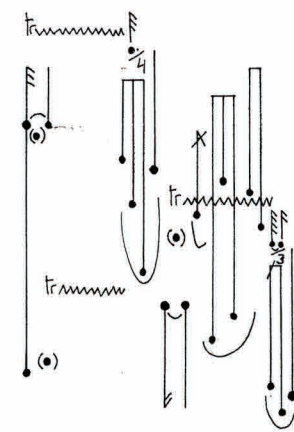
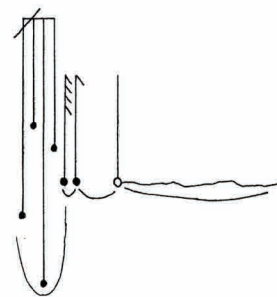
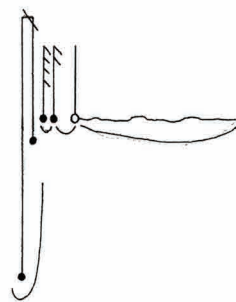
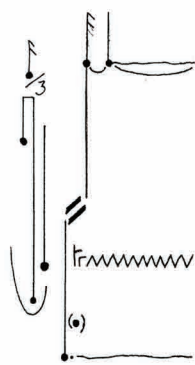
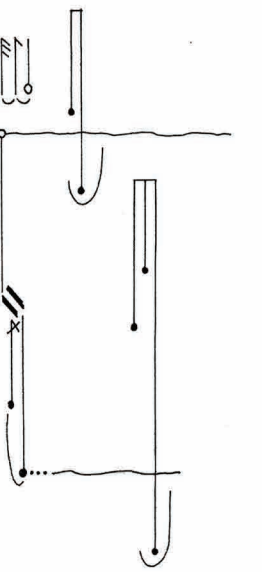
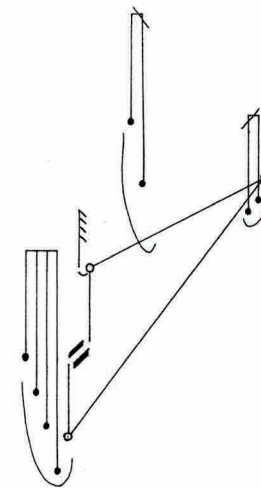
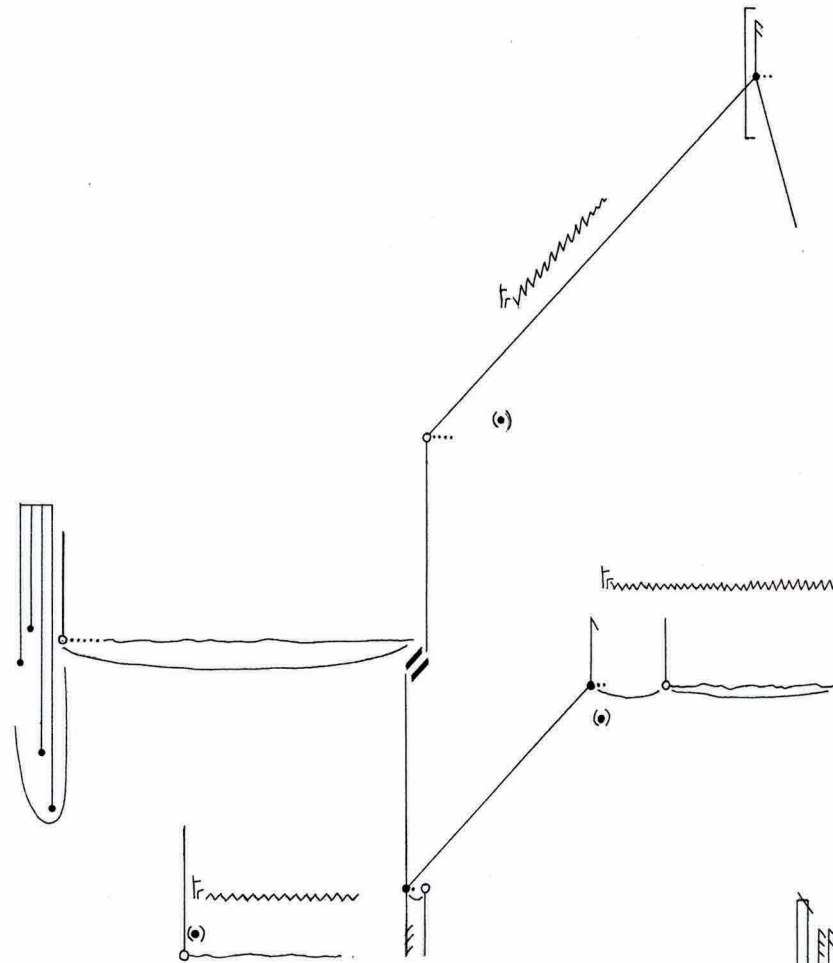
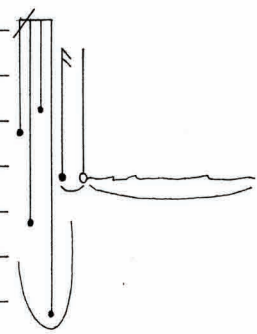
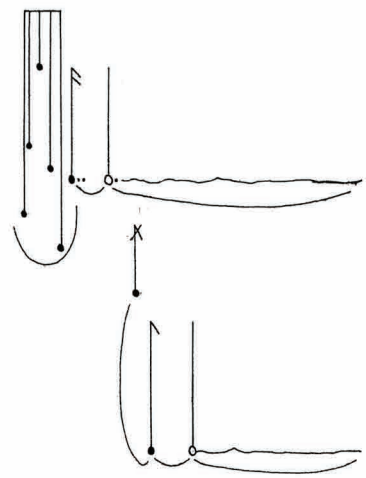
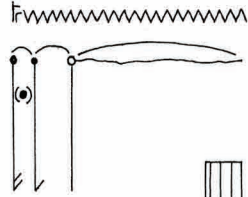

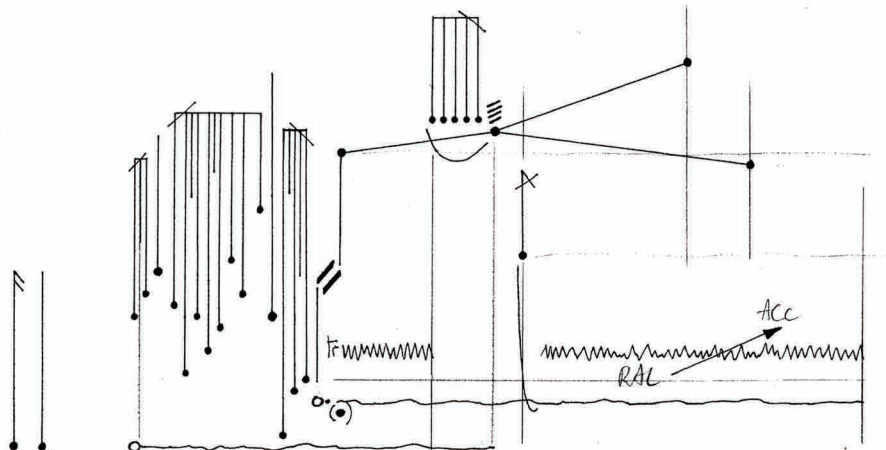
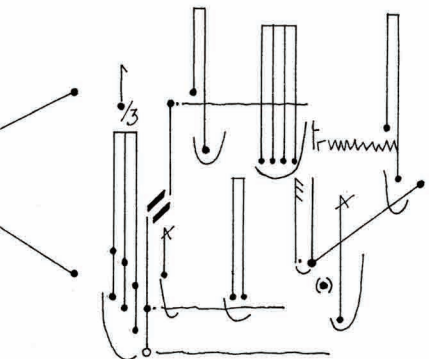
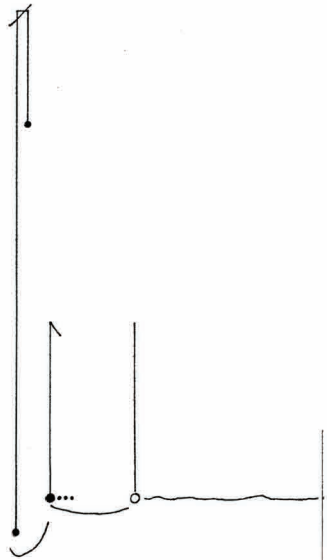
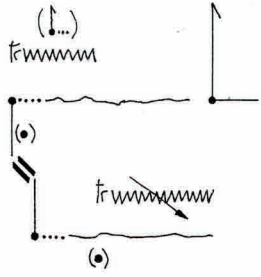

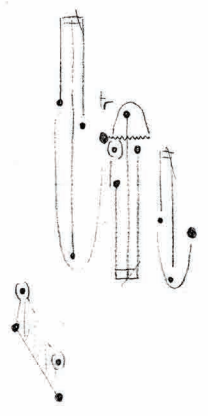
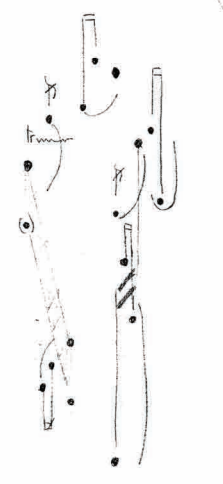
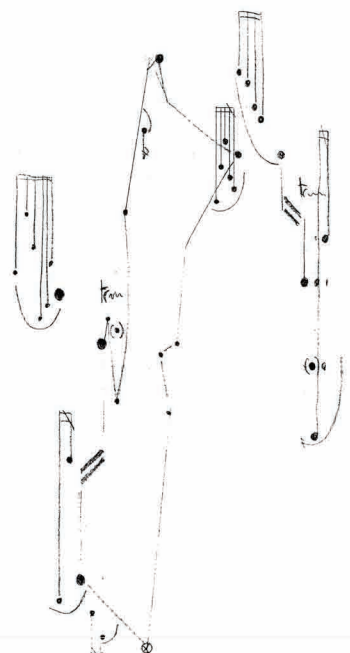

Tram

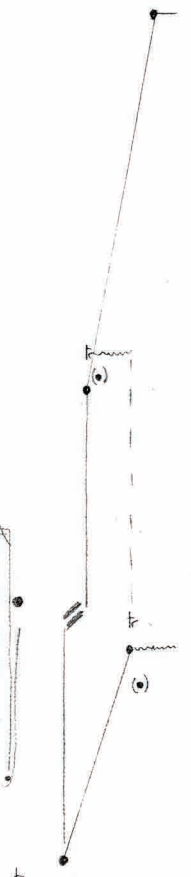

Tram

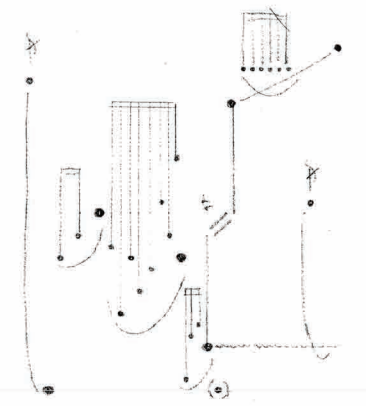
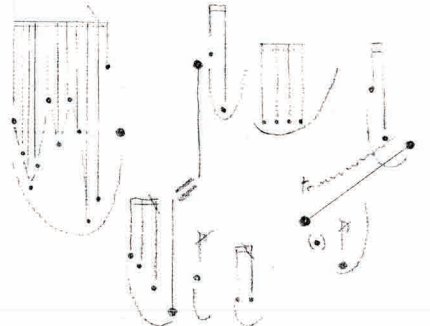
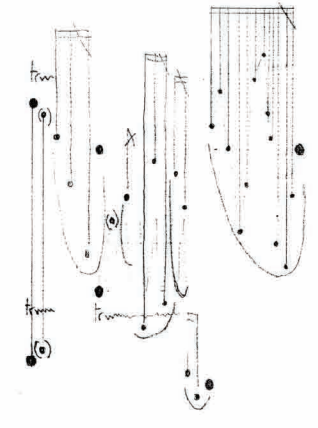
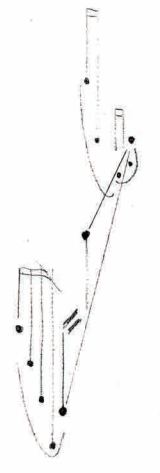

M.C.

Frottages sur vitres

HALLUCINANCE DE DÉTENSION

M.C.

Frottages sur vitres

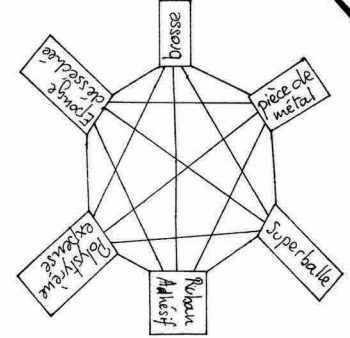

Frottages sur vitres

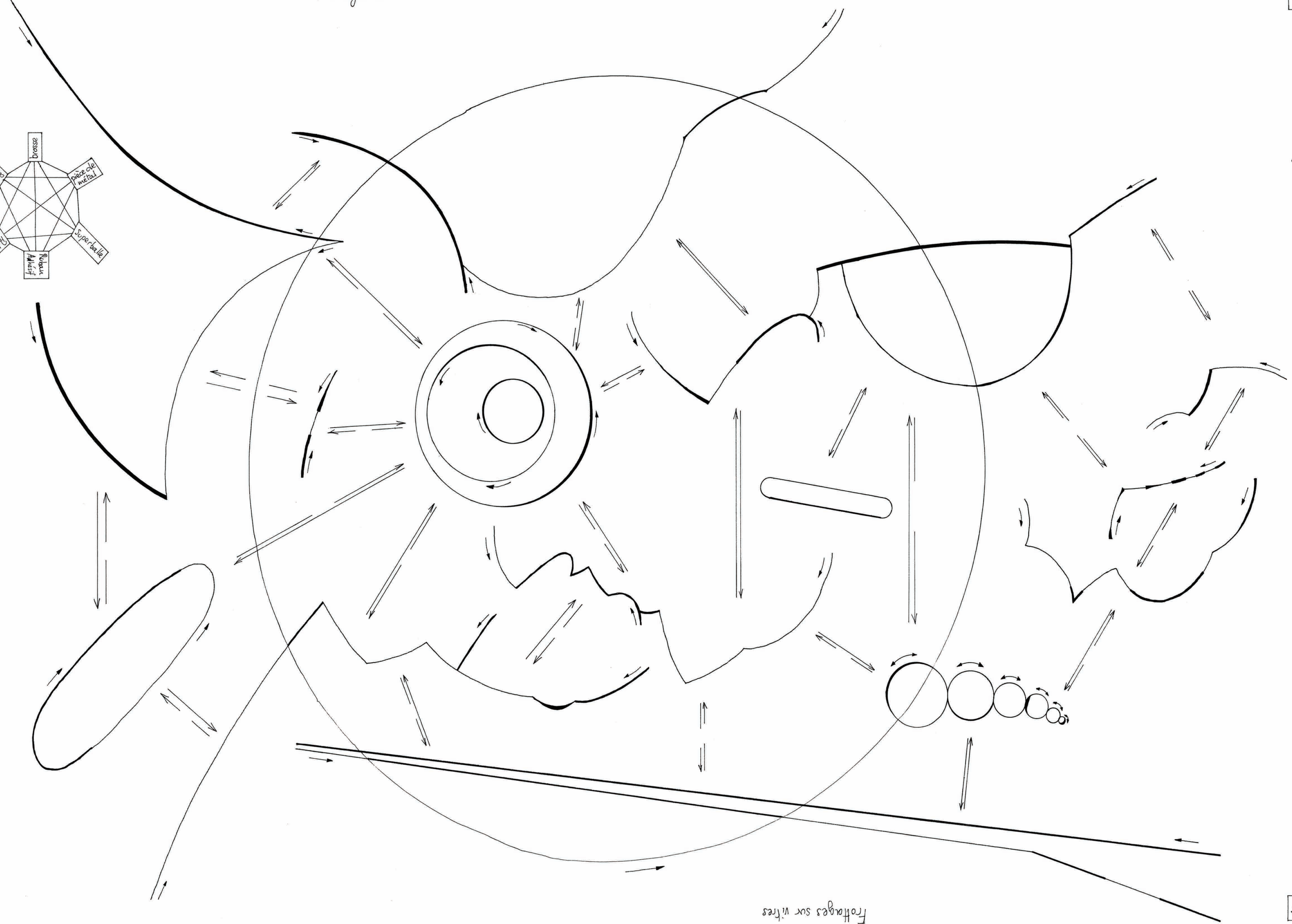

M.C.

Frottages sur vitres

M.C.

Recontraction progressive et totale
 Prestissimo ACC.
 Enfoucement

couplant

frisson de frotage

couplant

Enfoucement + frisson de frotage

f *2p* *f* *p*

FLASH

Son très lointain
 Son harmonique pur lisse
 Sourd.

ral. léger serrement
 a tempo via. sourd.
 ral. Angoisse
 acc.
 a tempo Ondulations
 le son enlève son enveloppe
 Serrement accru

Recontraction soudaine et totale
 ACC.
 Hyper claquage de cordes

ps. *3p* *2p* *2f* *3f* *4f*

Saturation max

FLASH

Son absent
 Son harmonique pur lisse
 Sourd.

via sourd.

le son se remplit

le son enlève son enveloppe

Recontraction soudaine et totale
 ACC.
 Hyper claquage de cordes

ps. *2p* *2f* *3f* *4f*

Intensité max

Traverse de son harmonique

ball Derive dans les rapides Chute noyade dans le vide

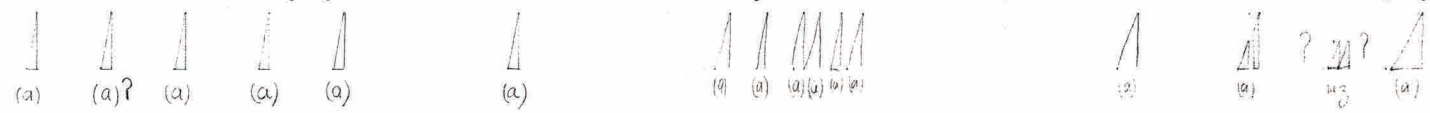
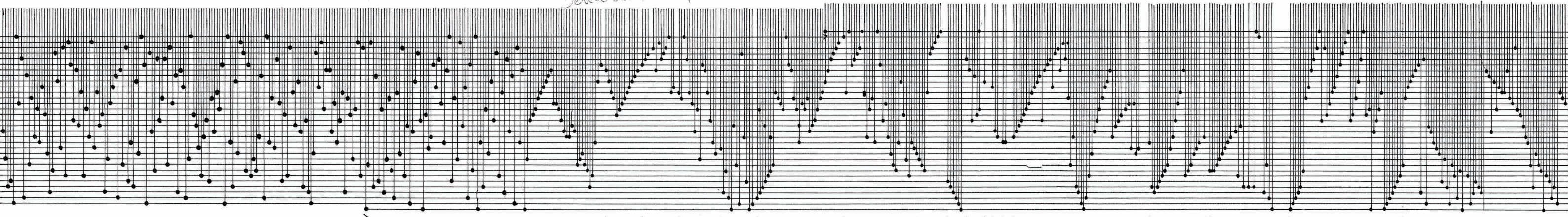

Agitation nerveuse extreme dans une habitude

limite de la resistance

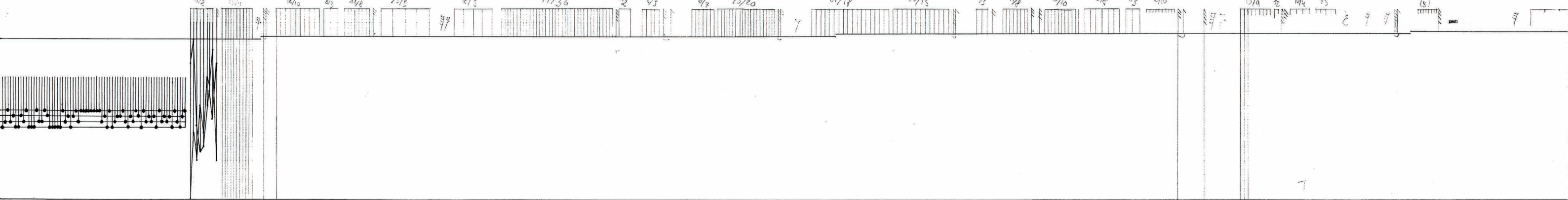

Tendo guttural sativo

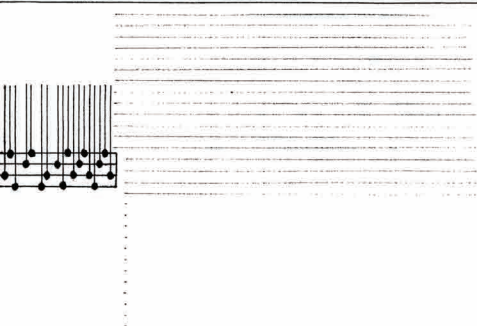

Un cascadeur plongeant à travers une vitre de 2m de côté (provoque l'arrêt brusque)

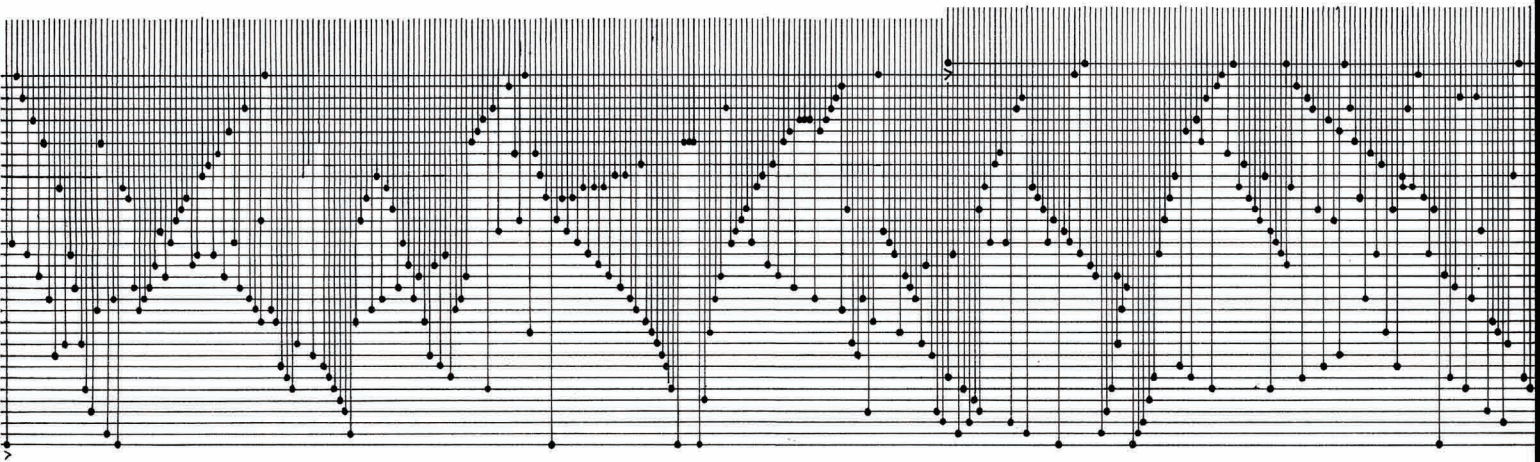

PARALYSIE HYSTERIQUE

Anémie astasique (entre la vie et la mort)

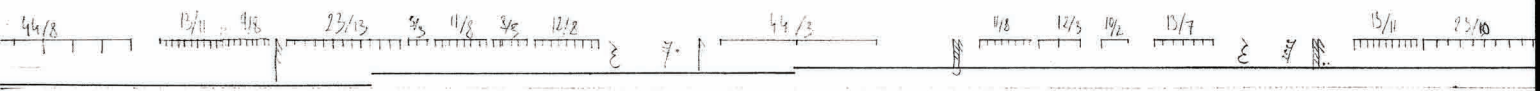

SOUDAIN LA PLUIE S'EST MISE A TOMBER →

PARALYSIE HYSTERIQUE

Anémie astasique (entre la vie et la mort)

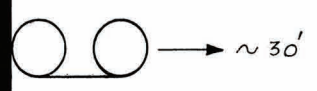

PARALYSIE HYSTERIQUE

Anémie astasique (entre la vie et la mort)

NOIR
VIDE

3" Top progressif

Top progressif

GRIS CLAIR

Bromela

BLANC SOLEIL
ROSE-BLEUE

Environ trois minutes après le début de la pluie, tout en jouant, 3 personnages en blancs apparaissent aux 3 coins opposés de la salle en poussant chacun devant eux une grande vitre jusqu'au centre de la salle. A un moment 3 gongs très graves cachés doubles les 3 grandes vitres.

Les 3 gongs disparaissent, les 3 joueurs de vitre s'éloignent en sens inverse.

Second souffle

Pendant la pluie; apparition, disparition: passage

Très doux, très lent sauf aux rencontres incomplètes, autre son.

37 + 79 -
53 + 79 -
29 + 79 -

le 1^{er} novembre 1982